

Pauluhn WashPro linear fluorescent luminaires

5L

Low bay luminaires for food and beverage and industrial locations

Applications:

- Locations requiring continuous and consistent light levels
- Food and beverage processing and storage
- Power generation facilities
- Water/wastewater treatment facilities

Features:

- High lumen output: up to 30,000 lumens
- Available in T8, T12 and T5HO fluorescent models
- NSF rated
- Operating ambient: -20°C to +55°C
- High pressure hose down rated to 1,500 PSI

Certifications and compliances:

- UL1598 – Luminaires (CSA-US)
- UL924 – Emergency Lighting Equipment (CSA-US)
- CSA 22.2 No. 250-4
- Canadian Processed Products Regulations C.R.C., c.291
- NSF/ANSI 2-2010 Food Contact (WPS only)
- NSF/ANSI 2-2010 Splash Zone

Photometrics:

- Complete photometrics can be found at www.crouse-hinds.com/photometrics



Standard materials:

- Housing – end caps non-metallic or stainless steel (standard); polycarbonate center stud (optional)
- Lens – acrylic
- Gasket – neoprene
- External hardware – stainless steel

Ordering information:

Part number example
WP82870EM2

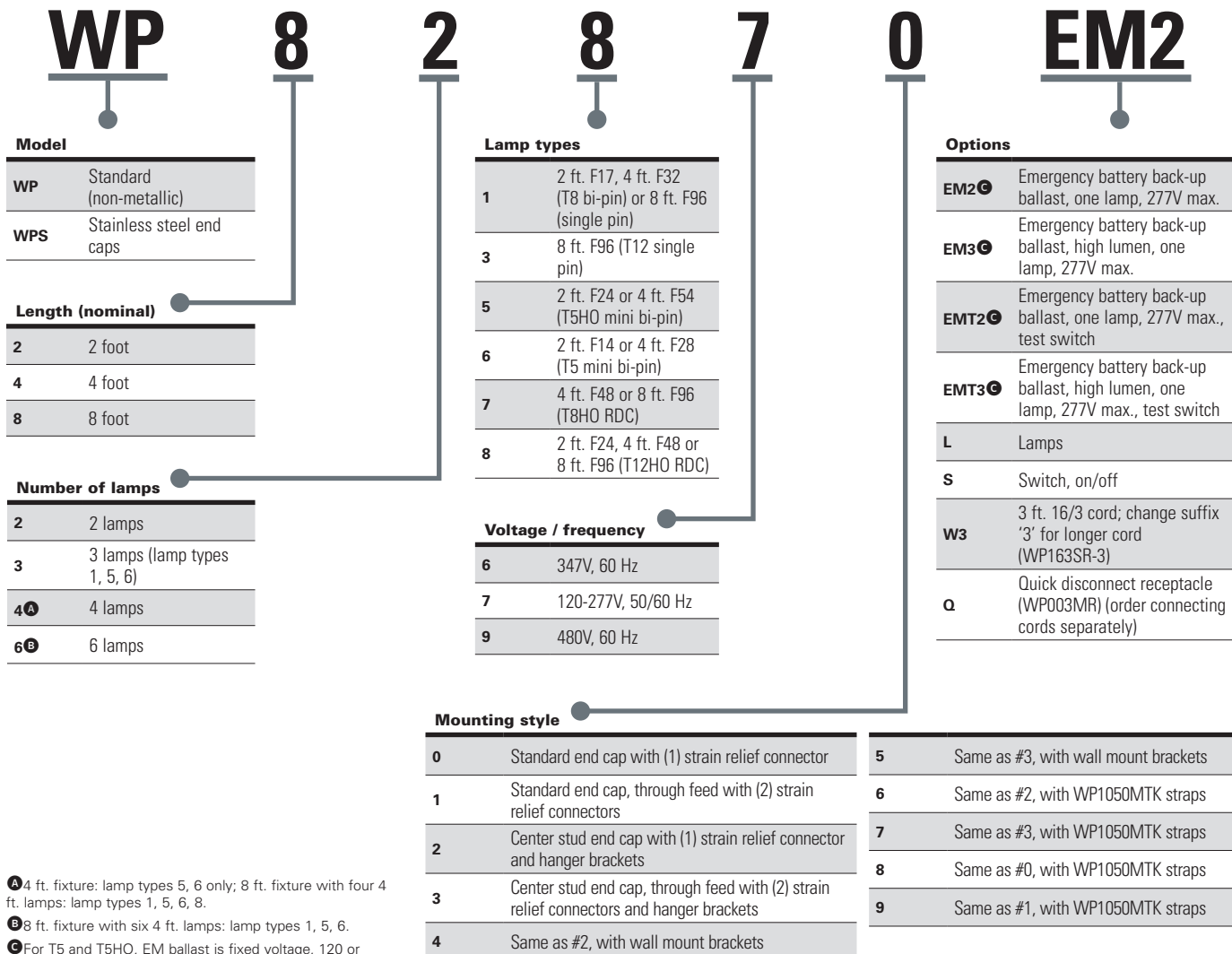

^A 4 ft. fixture: lamp types 5, 6 only; 8 ft. fixture with four 4 ft. lamps: lamp types 1, 5, 6, 8.

^B 8 ft. fixture with six 4 ft. lamps: lamp types 1, 5, 6.

^C For T5 and T5HO, EM ballast is fixed voltage, 120 or 277V, 50/60 Hz.

Pauluhn WashPro linear fluorescent luminaires

5L

Low bay luminaires for food and beverage and industrial locations

Mounting options and accessories:

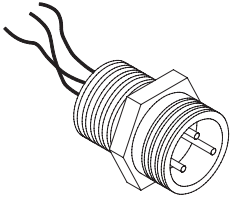

WP003MR

Quick disconnect receptacle
Required when WP163-6 cord assembly is used.

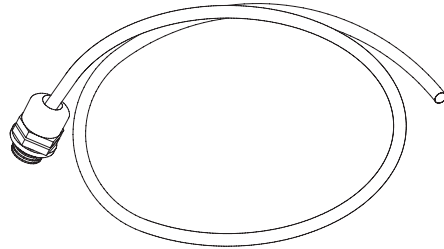

WP163SR-6

Cord assembly
Strain relief connector and 6 feet of #16/3 cable. If longer cable is required, change '6' suffix to length needed.

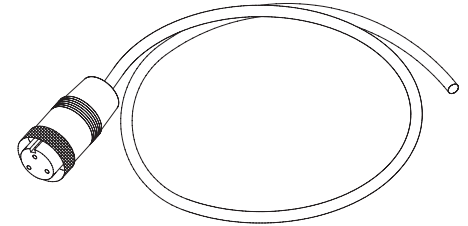

WP163FP

Cord assembly
Molded plug and 6 feet of #16/3 cable. If longer cable is required, change '6' suffix to length needed.

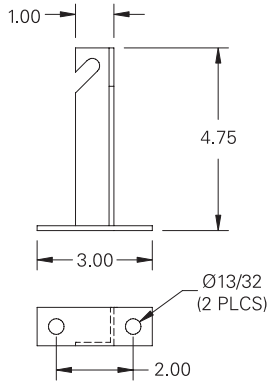

FX7090

Wall mount bracket
For center stud end caps.

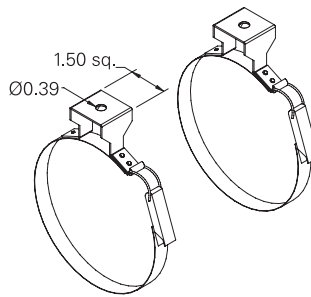

WP1050MTK

Quick release stainless steel straps
(2) included with mountings 6, 7, 8, 9.

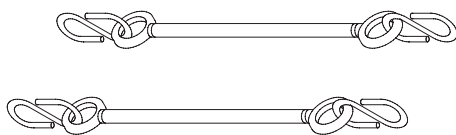

WP1012MTK

Suspended cable kit
(2) 12 inch nylon coated stainless steel cables with crimped-on loops; (2) "S" hooks.

(if longer cable required, change '12' in catalog number to required length)

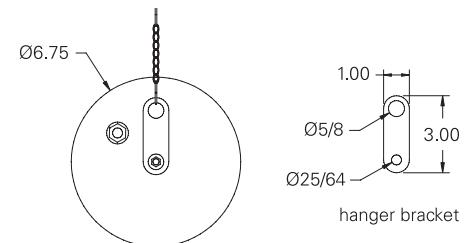
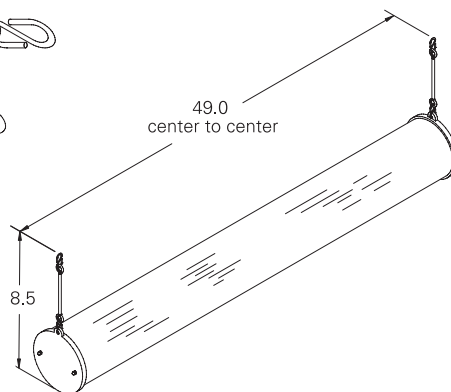

Center stud end cap

Includes hanger bracket and stainless steel chain mount.
(mountings 2 & 3)

Pauluhn WashPro linear fluorescent luminaires

5L

Low bay luminaires for food and beverage and industrial locations

Dimensions:

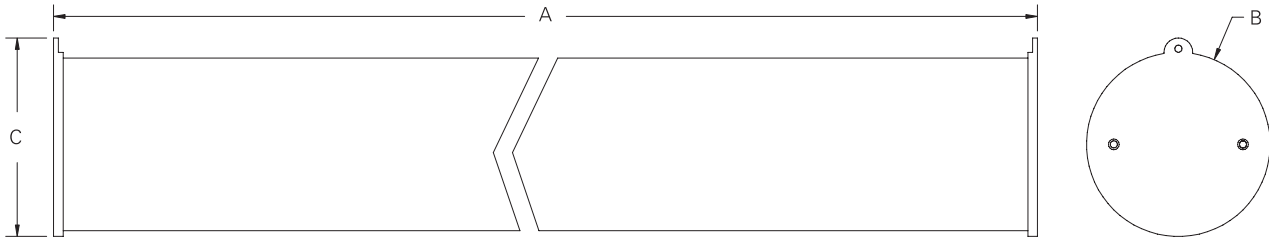

Nominal length	Dimensions in inches / centimeters			Carton W x D x L (in.)	Nominal weight	
	A	B	C		Lbs.	Kg.
2 foot	25.00 (63.50)	6.40 (16.30)	7.03 (17.86)	8 ⁵ / ₄ x 6 ¹ / ₄ x 31 ¹ / ₈	12.40	5.60
4 foot	49.00 (124.50)	6.40 (16.30)	7.03 (17.86)	8 x 8 x 51 ¹ / ₄	20.30	9.20
8 foot	97.00 (246.40)	6.40 (16.30)	7.03 (17.86)	8 x 8 x 99 ¹ / ₄	36.10	16.40

5L